

A Rotazione di 360°
(cambiamento di direzione)

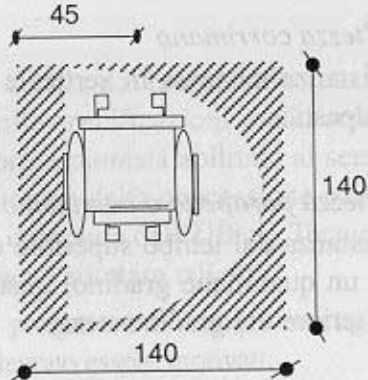

B Rotazione di 180°
(inversione di direzione)

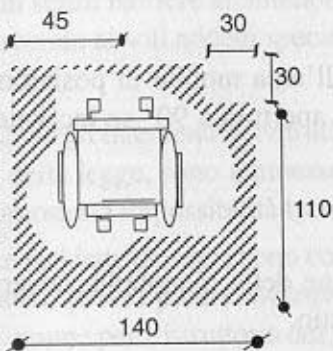

C Rotazione di 90°

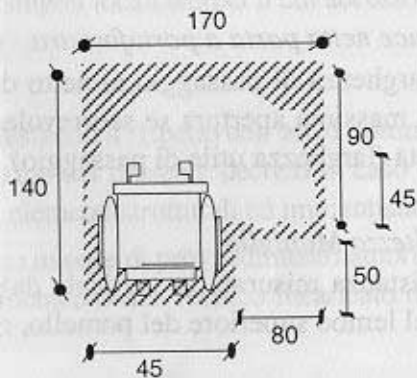

D Svolta di 90°

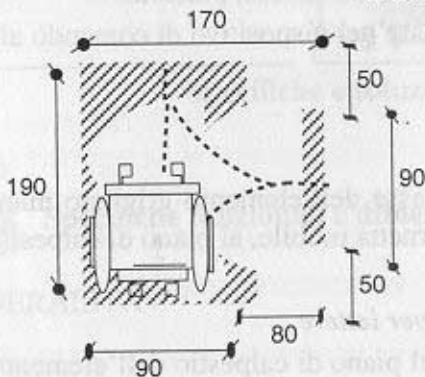

E Inversione di direzione
con manovra composta

 In casi di adeguamento e per consentire la visitabilità degli alloggi, ove non sia possibile rispettare i dimensionamenti di cui sopra, sono ammissibili i seguenti spazi minimi di manovra (manovra combinata):

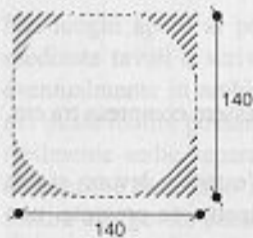

F Rotazione di 360°
(cambiamento di direzione)

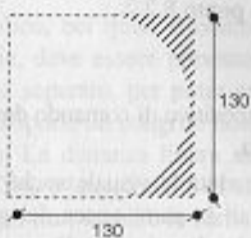

G Rotazione di 180°
(inversione di direzione)

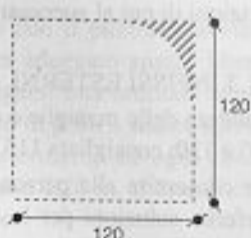

H Rotazione di 90°

8.1.1 PORTE

La luce netta della porta di accesso di ogni edificio e di ogni unità immobiliare deve essere di almeno 80 cm. La luce netta delle altre porte deve essere di almeno 75 cm.

Gli spazi antistanti e retrostanti la porta devono essere dimensionati nel rispetto dei minimi previsti negli schemi grafici di seguito riportati.

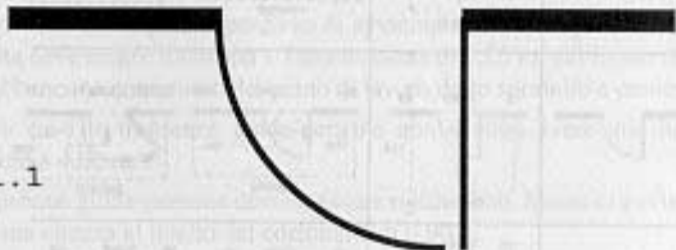

minimo cm. 75

Spazi liberi minimi per il passaggio di porte

8.1.1

8.1.1.2

Spazi antistanti e retrostanti la porta (segue 8.1.1 – Porte)

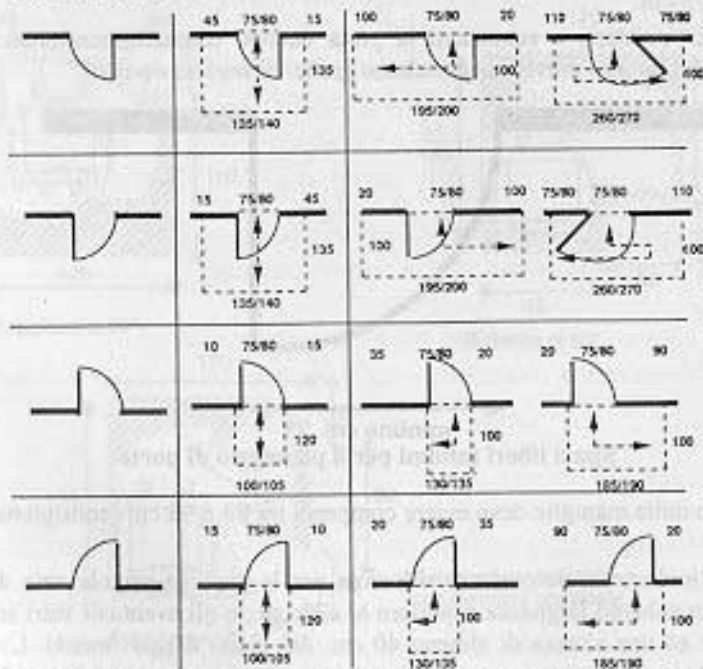

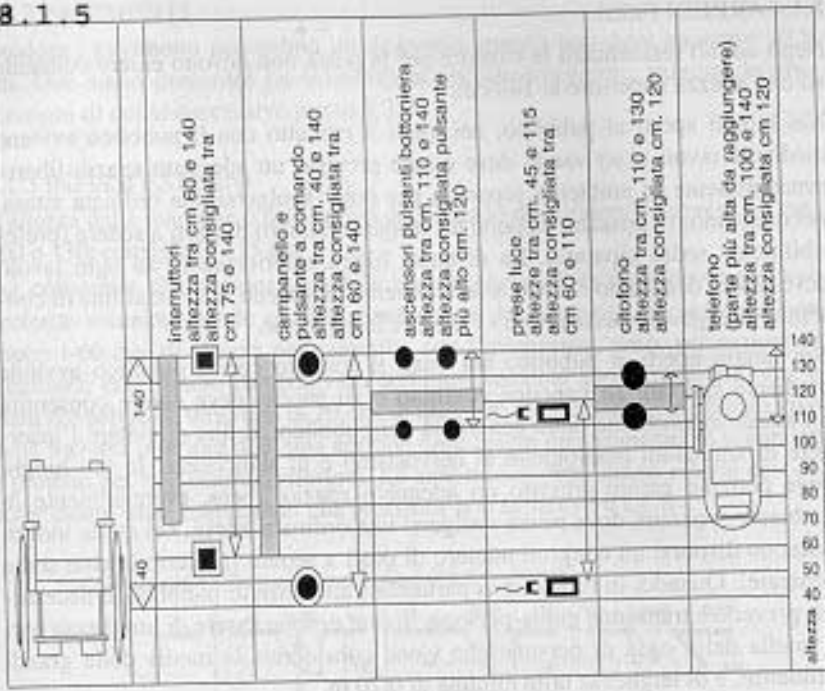

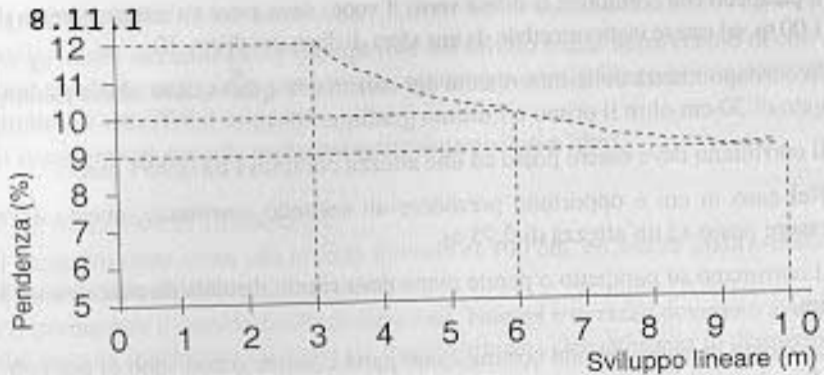

9.1.a1

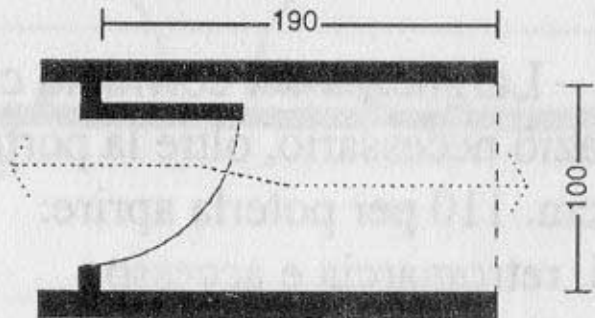

A1

9.1.a2

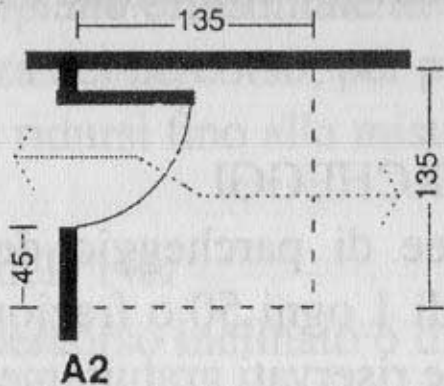

9.1.a3

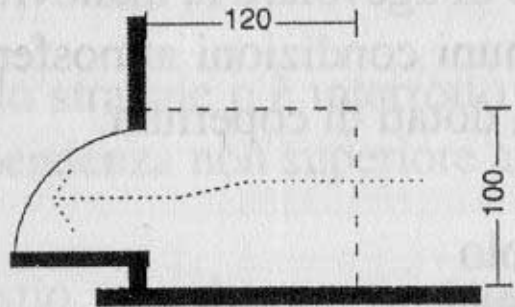

A3

9.1.b1

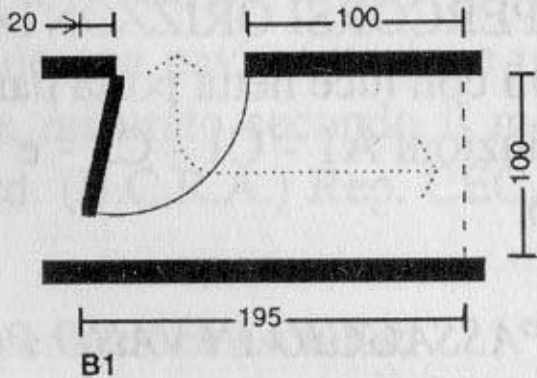

9.1.b2

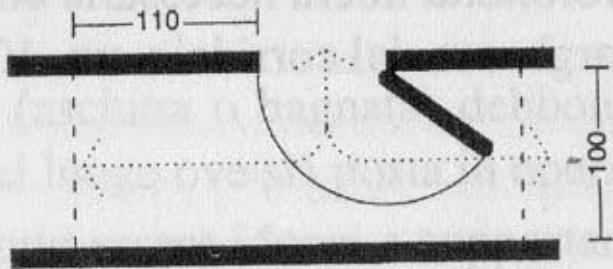

B2

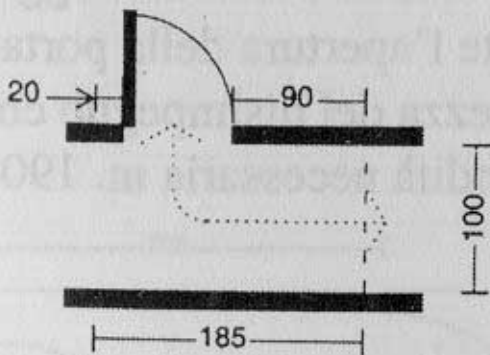

B3

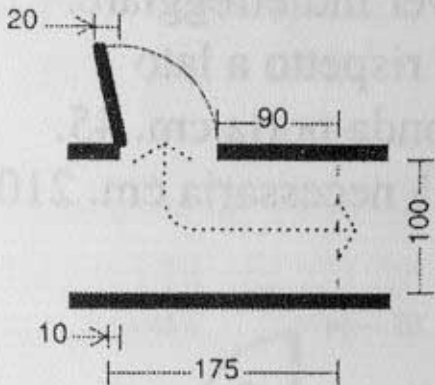

B4

190 120

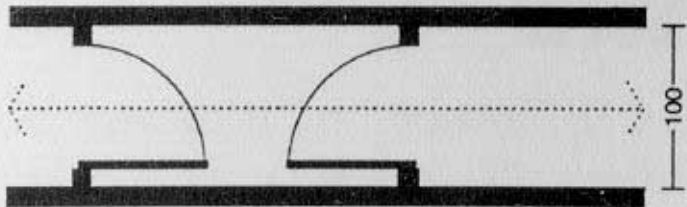

c1

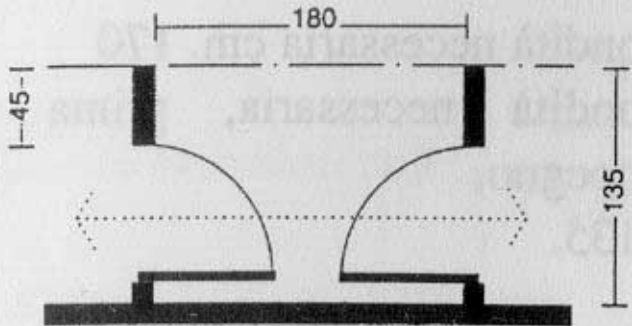

C2

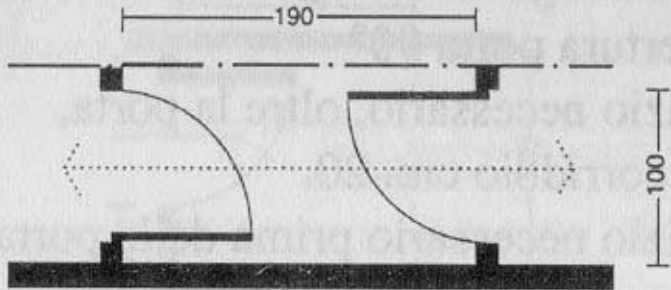

C3

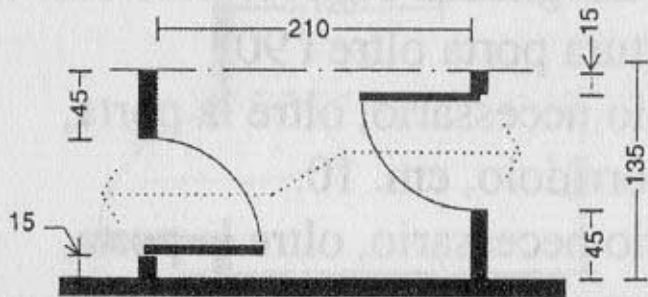

C4

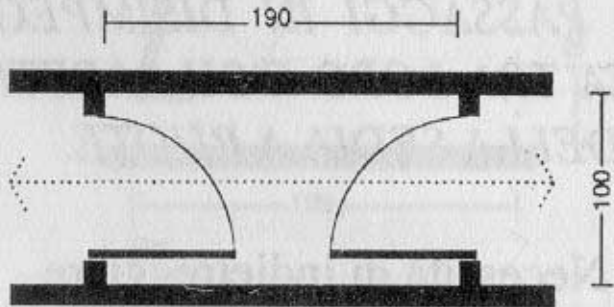

C5

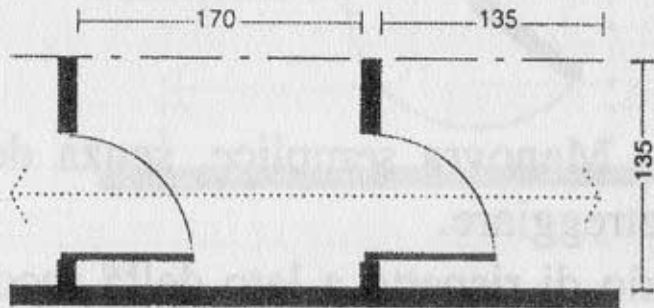

C6

